

SWEDISH • AUDIO • PASSION

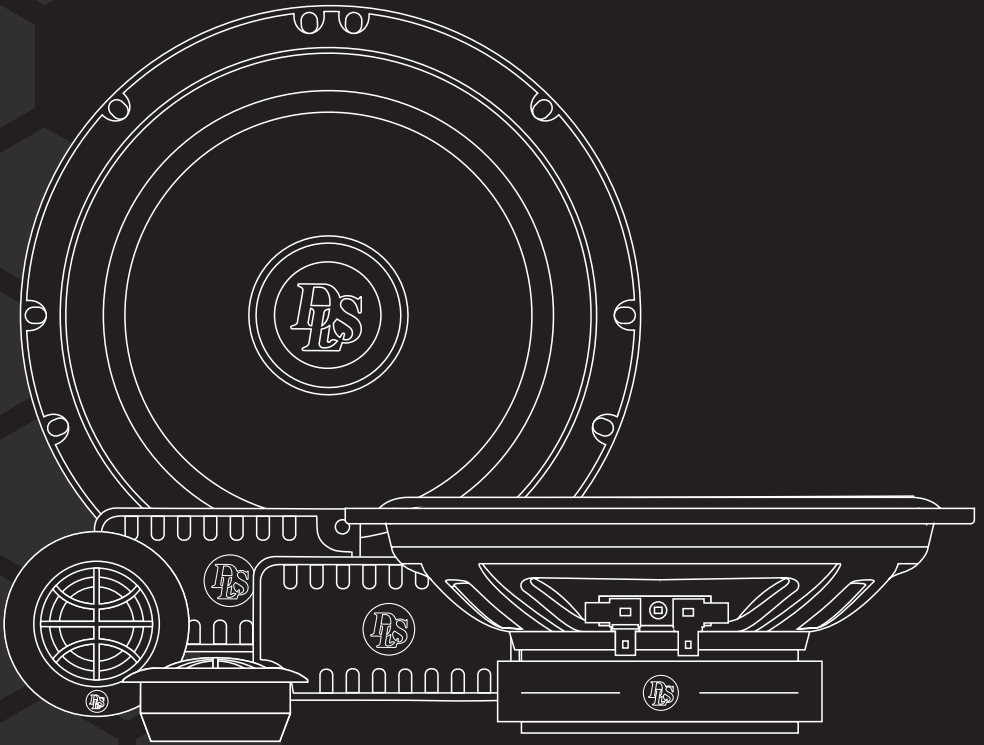

PA6.20

User manual



PERFORMANCE

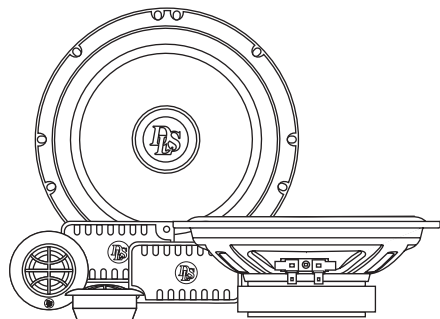

Welcome to DLS!

Thank you for buying a DLS Performance PA6.20. For us, it's all about the sound experience. We care deeply about sound and construction quality. In order for your experience to be as optimal as possible, it is important that you read this manual, preferably before you start your installation. Keep the manual in a safe and accessible place for future reference.

Your speakers must be installed correctly in order to work as intended. Make sure you have all necessary tools nearby before starting and that you are completely confident in how to process. If you feel the slightest uncertainty, feel free to take the help of an experienced installer or a car audio dealer.

Warranty

This component kit is covered by warranty, depending on the conditions in the country where it is sold. If the speaker is returned for service, please include the original dated receipt with the product.

General

Some sound systems may vary in size of the door speaker. Make sure that your vehicle has the same size as this kit, before you start the assembly

DECLARATION OF CONFORMITY

DLS plug and play speakers for vehicles are manufactured in accordance with the EU directive EEC 95/54 (72/245/EEC) and are marked with the approval number. They are also marked in accordance with the WEEE-directive 2012/19/EC. The products are also produced in accordance with the EU RoHS directive 2015/863/EU.

DLS PERFORMANCE

PA2.60

Content

Welcome	1
Warranty	1
General	1
Declaration of conformity	1
Included parts	2
Pre installation	2
Installation	2
Running-in time	3
DLS support	3
Wiring diagram	4
Specifications	5
Product markings	6

DLS speakers are engineered by DLS Sweden,
a part of:

Winn Scandinavia AB

Elementvägen 15 - SE-702 27 Örebro - Sweden

Tel: +46 19 20 67 65 - E-mail: info@dls.se

www.dls.se

Designed & Sound tuned in Sweden.



Included parts

Included products:

- 2pcs Woofer
- 2pcs Tweeter
- 2pcs Crossover (including 2 x 50cm cable)

Included in box:

- 2pcs Tweeter bottom adapters
- 2pcs Tweeter cable 100cm (for loose ends)
- 2pcs Adhesive foam
- 8pcs V-type clips
- 8pcs Screws
- 2pcs Grills
- 1pcs Manual

Pre installation

Disconnect Battery

Before you start the process of replacing speakers, disconnect and secure the negative terminal from your battery/power source. This will prevent the risk of damaging yourself or the products.

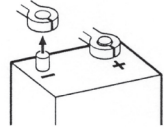

Place the disconnected terminal in a secure and isolated location away from any possible connection belonging to the battery/power source system.

Installation

Mount the speakers in the door or in the dashboard of your car. They may fit in the factory pre-made mounting holes, if not you might have to modify the fitting. If you want to improve the sound reinforcement you can use a baffle of MDF-board or similar. An installation high up on the door side is to be preferred. For door placements, there are normally speaker rings that have to be used to make the speaker fit to the door panel.

In many vehicles there are factory made places for tweeters that you can use for installation. If this is not possible, try to install the tweeter close to the bass/midrange driver. The tweeter can also be installed on the dash-board, or recessed in the door with the accessories included with the tweeters. **NOTE!** It is important to fasten the speakers properly in order to avoid bad sound or rattling. Connect the speakers and crossovers as in the drawing below.

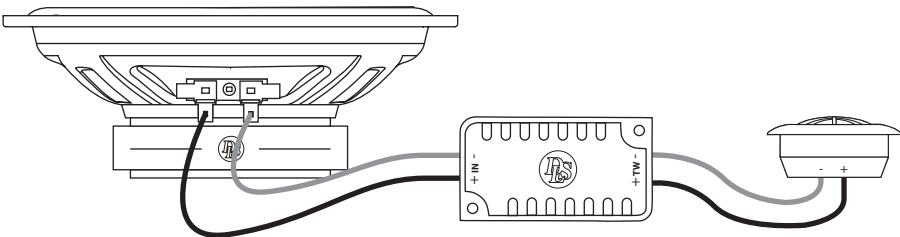

Installation of tweeter

The tweeter can be mounted on the dashboard with the included angled housing, or recessed in a door side.

Surface mounting

Put the cable through the hole in the rear end of the angled housing. The tweeter is attached to it by putting them together and turn clockwise. Attach the housing to the surface with the included double adhesive tape.

Recessed mounting

You need a hole with a diameter of 43 mm/1.7". Use glue to attach the recessed housing to the A-pillar, or door panel. The tweeter is attached to the housing by putting the tweeter into it and turning clockwise.



Door insulation

DLS recommends using insulation/sound deadening in the car doors. It lowers the noise from the road/tires and prevent rattles and other noises from plastic details in the doors.

If you need help deciding what type of door insulation you should use, ask your DLS distributor for info and guidance.

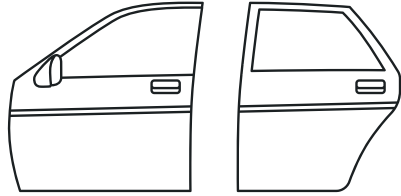

Running-in time

Allow the component kit to play for at least 15-20 hours in order to perform at its possibly best. This run-in can be made with tone sweep or with just music.

Start at a moderate volume and increase the volume step by step during the running in period. After the 15-20 hour run in session the performance and characteristics will be in the correct condition.



DLS support

For technical assistance, ask your car audio dealer where the product was sold or the distributor in your country. You can always contact the DLS Helpdesk in Sweden at e-mail: info@dls.se Information can also be found on our WEB-site www.dls.se We follow a policy of continuous advancement in development. For this reason, all or part of specifications & designs may be changed without prior notice.



Wiring diagram

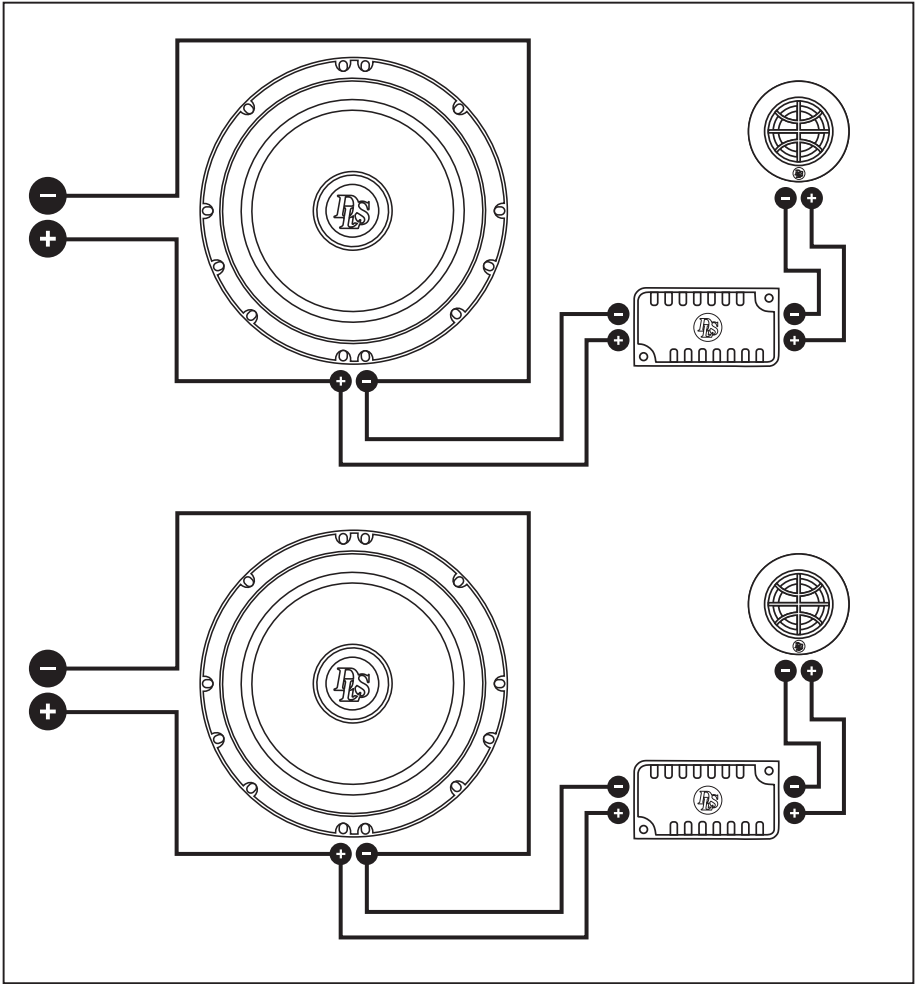



Specifications

Art. no PA6.20

Woofer 6.5" /165 mm with polypropylene cone

Tweeter 0,8" / 20 mm silk dome tweeter

RMS Power 60W

MAX Power 120W

PEAK Power 180W

Impedance 4 Ohm

Sensitivity 89dB 1W/1M

Freq. range 65Hz-20kHz

Crossover 5kHz 12dB/Oct

DLS PA6.20 Tweeter

Technical Specification

Size 0,8" /20 mm

RMS Power 40W

MAX Power 80W

PEAK Power 120W

Frame Reinforced ABS

Magnet Neodymium

Cone Natural silk dome

Impedance 4 ohm

Freq. range 3000Hz-20kHz

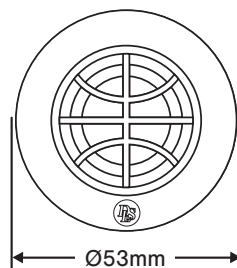
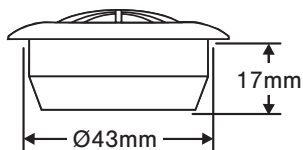

DLS PA6.20 Woofer

Technical Specification

Size 6,5" /165 mm

RMS Power 60W

MAX Power 120W

PEAK Power 180W

Basket Steel

Magnet Ferrite

Cone Polypropylene

Impedance 4 ohm

Freq. range 65Hz-5kHz

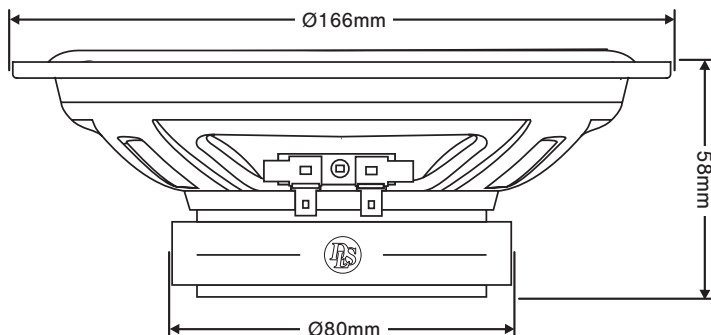



Product markings



The crossed-out wheelee bin symbol means that the product, literature and packaging included must be taken to separate collection at the end of their working life. Do not dispose of these products as unsorted municipal waste: take them for recycling. For info on your nearest recycling point, check with your local waste authority.



This product has been granted with the CE certification mark to show that the product follows the health, safety, and environmental protection standards for products sold within the European Economic Area (EEA).



DLS products complies with the relevant provisions of the RoHS Directive for the European Union. In common with all Electrical and Electronic Equipment (EEE) the product should not be disposed of as household waste. Alternative arrangements may apply in other jurisdictions.



DLS is a global partner of the European Mobile Media Association, an organisation that focus on promoting the custom made mobile media installations to consumers.

We follow a policy of continuous advancement in development. For this reason all or part of specifications & designs may be changed without prior notice. We reserve for possible typos, factual or numeric errors that may have been printed on any products, package designs, user manuals and/or other included accessories.



PERFORMANCE