



...connecting to the aftermarket

INSTALLATION INSTRUCTIONS FOR PART CT24CH07

APPLICATIONS

Chrysler Sebring 2007
Chrysler Town and Country 2008
Dodge Avenger 2007-2008
Dodge Dakota 2008
Dodge Grand Caravan 2008
Dodge Nitro 2007

Jeep Wrangler 2007

(Modifications To Radio Cavity Required)

CT24CH07

KIT FEATURES

- Double DIN Radio Provision
- Stacked ISO Units Provision

KIT COMPONENTS

A) Double DIN Brackets/Trim Plates



A

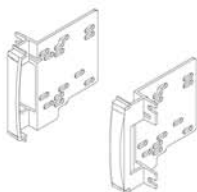

TOOLS REQUIRED:

Small Flat Blade Screwdriver/ Panel Removal Tool

- Phillips Screwdriver • Socket Set



www.connects2.com

TABLE OF CONTENTS

Dash Disassembly

- Chrysler Sebring 2007	1
- Chrysler Town and Country 2008	2,3
- Dodge Avenger 2007-2008	4
- Dodge Dakota 2008	5
- Dodge Grand Caravan 2008	2,3
- Dodge Nitro 2007	6
- Jeep Wrangler 2007 (Modifications to radio cavity required)	7

Kit Assembly

- Double DIN Radio Provision	8
- Stacked ISO Units Provision	9

<u>Final Assembly</u>	10
------------------------------------	----

***Note:**

Refer also to the instructions included with the aftermarket radio.

CHRYSLER SEBRING 2007

- 1** Disconnect the negative battery terminal to prevent an accidental short circuit.
- 2** Unclip entire panel surrounding radio including a/c vents and clock. Unplug and remove panel. (Figure A)
- 3** Remove (4) 7MM screws securing radio. Unplug and remove radio. (Figure B)

Continue to kit assembly.

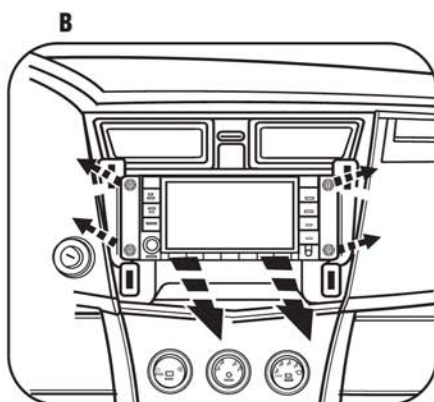
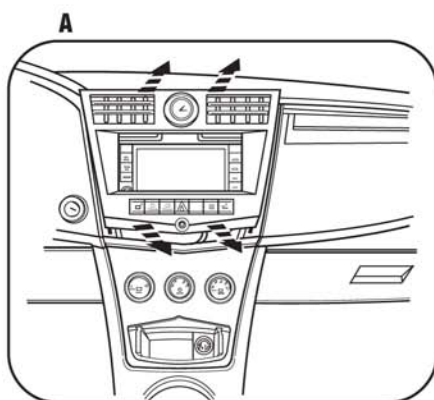

CHRYSLER TOWN AND COUNTRY 2008 **DODGE GRAND CARAVAN 2008**

- 1 Disconnect the negative battery terminal to prevent an accidental short circuit.
- 2 Remove (2) screw covers facing up above radio then remove the (2) Phillips screws exposed. (Figure A)
- 3 Lift up on panel above radio then remove (2) Phillips screws exposed at front edge of radio trim panel. (Figure B)
- 4 Remove (3) plastic push pins per side of bottom trim panel then slide panel toward rear of van to access (2) screws on bottom of radio trim panel. (Figure C)

Continued on page 3.

A

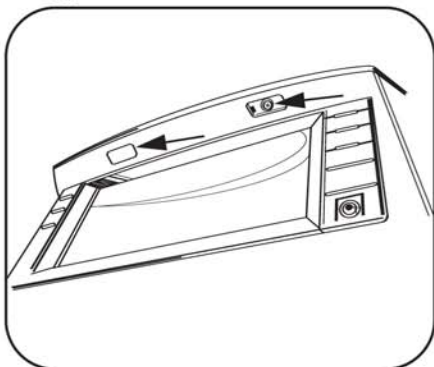

B

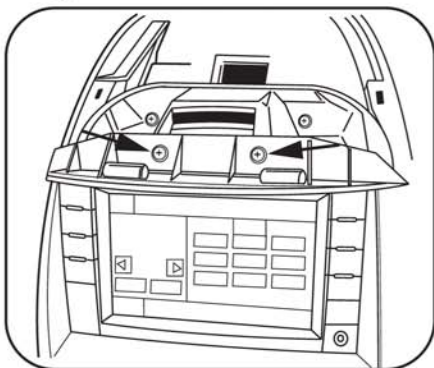

C

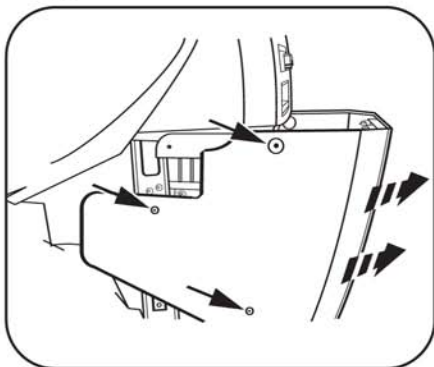

CHRYSLER TOWN AND COUNTRY 2008 **DODGE GRAND CARAVAN 2008**

- 5 Remove (2) Phillips screws exposed at bottom edge radio trim panel. (Figure D)
- 6 Unclip and remove entire panel surrounding radio including climate controls, vents and clock. (Figure E)
- 7 Remove (4) Phillips screws securing radio. (Figure F)

Continue to kit assembly.

D

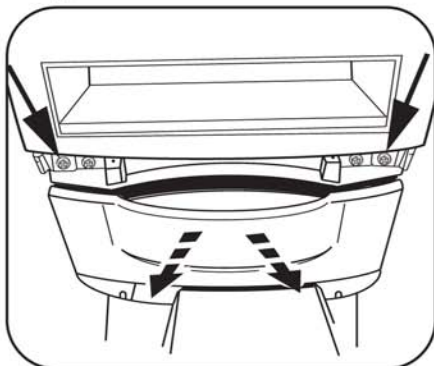

E

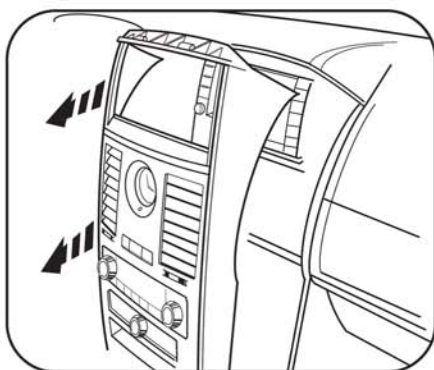

F

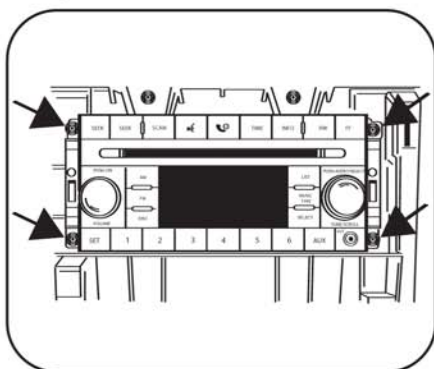

DODGE AVENGER 2007-2008

- 1** Disconnect the negative battery terminal to prevent an accidental short circuit.
- 2** Unclip and remove the center console trim panel. (Figure A)
- 3** Unclip the center dash trim panel. (Figure B)
- 4** Remove (4) screws securing the radio. Disconnect and remove the radio. (Figure C)
- 5** Remove (3) screws securing the radio rear support bracket and remove the bracket. (Figure D)

Continue to kit assembly.

A

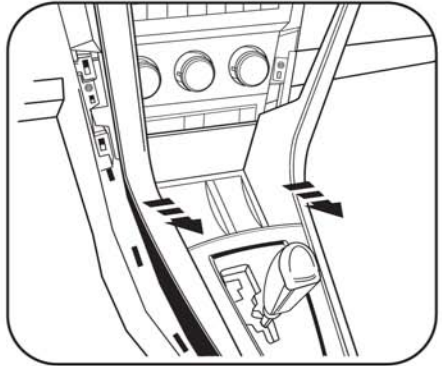

B

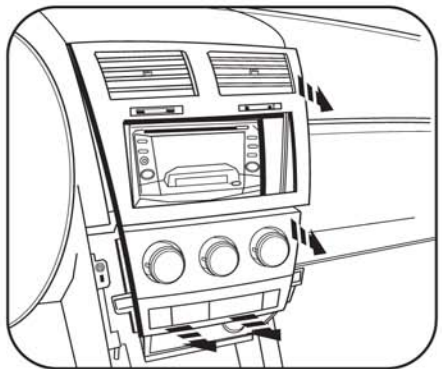

C

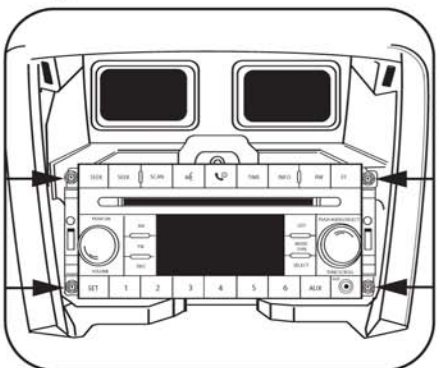

D

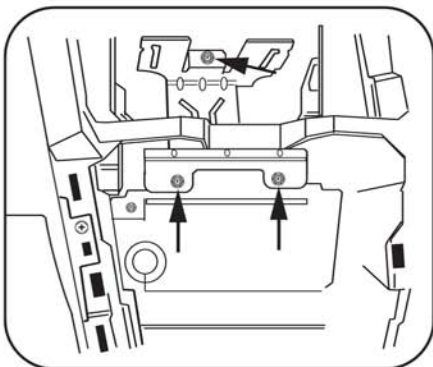

DODGE DAKOTA 2008

- 1** Disconnect the negative battery terminal to prevent an accidental short circuit.
- 2** Unclip and remove the trim panel surrounding the radio. (Figure A)
- 3** Remove (4) Phillips screws securing the radio. (Figure B)

Continue to kit assembly.

A

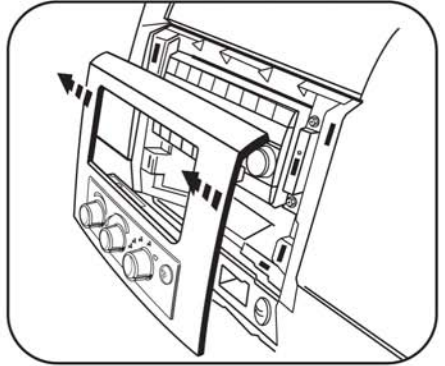

B

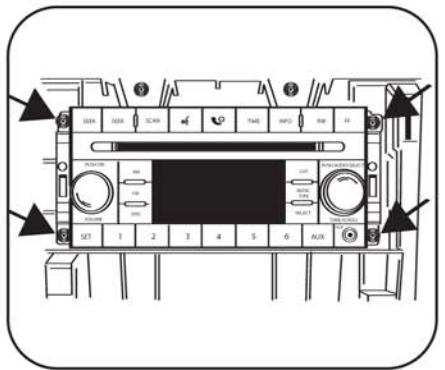

DODGE NITRO 2007

- 1** Disconnect the negative battery terminal to prevent an accidental short circuit.
- 2** Unclip entire panel surrounding radio and climate controls, including a/c vents. Unplug and remove panel.
- 3** Remove (4) 7MM screws securing radio. Unplug and remove radio. (Figure B)

Continue to kit assembly.

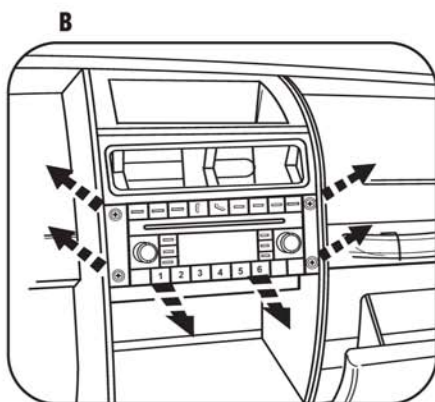
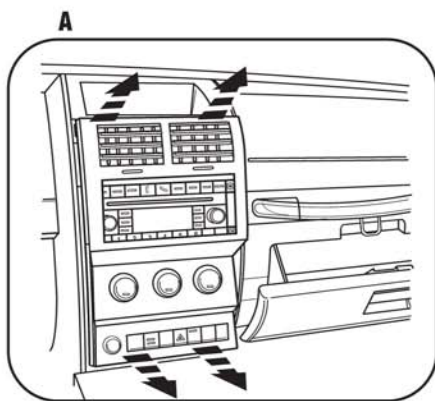

JEEP WRANGLER 2007

(Modifications To Radio Cavity Required)

- 1** Disconnect the negative battery terminal to prevent an accidental short circuit.
- 2** Unclip and remove the lower center trim below a/c controls. (Figure A)
- 3** Remove (2) Phillips screws exposed behind lower center panel. (Figure A)
- 4** Unclip and remove the upper center trim starting towards the rear of the panel. (Figure A)
- 5** Remove (2) Phillips screws exposed behind upper center panel. (Figure A)
- 6** Unclip and remove entire panel surrounding radio and climate controls, including a/c vents.
- 7** Remove (4) 7MM screws securing radio. Unplug and remove radio. (Figure B)

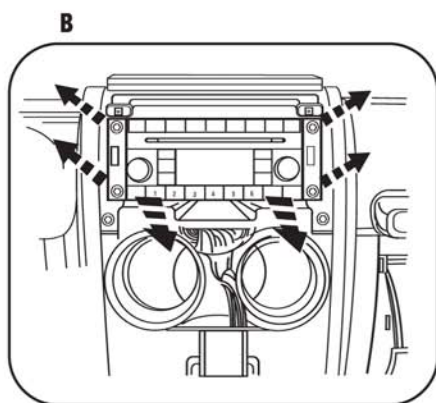
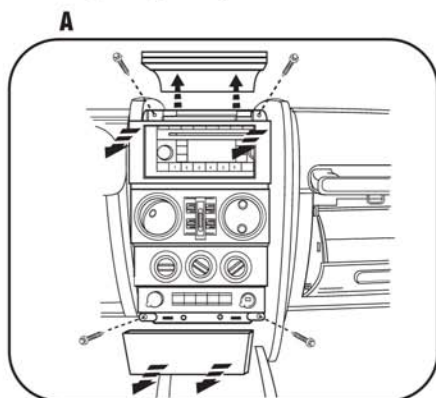

Continue to kit assembly.

DOUBLE DIN RADIO PROVISION

**Note: Refer also to the instructions included with the aftermarket radio.*

- 1 Attach the Double DIN brackets/trim plates to the Double DIN Radio using the screws supplied with the Radio. (Figure A)

Continue to final assembly.

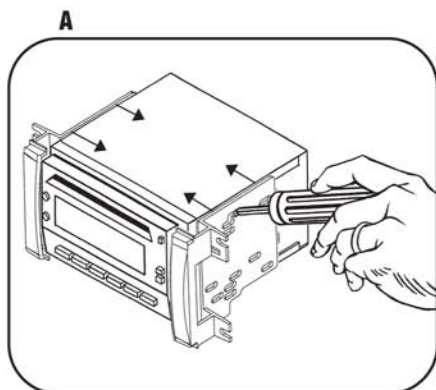

STACKED ISO UNITS PROVISION

**Note: Refer also to the instructions included with the aftermarket radio.*

- 1 Attach the Double DIN brackets/trim plates to the stacked ISO units using the screws supplied with the units. (Figure A)

Continue to final assembly.

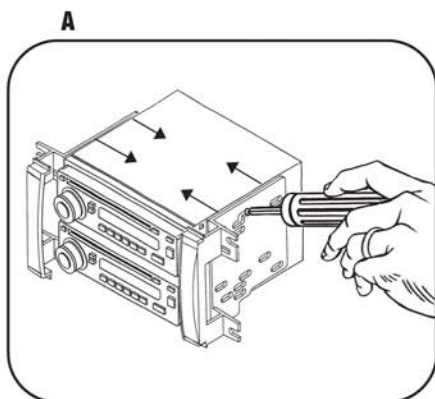

FINAL ASSEMBLY

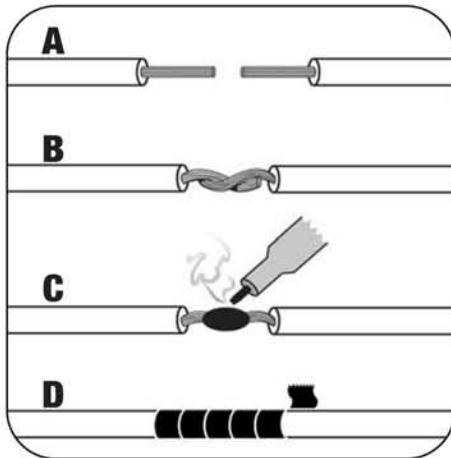

- A) Strip wire ends back 1/2"**
- B) Twist ends together**
- C) Solder**
- D) Tape**

- 1** Locate the factory wiring harness in the dash. Metra recommends using the proper mating adapter and making connections as shown. (Isolate and individually tape off the ends of any unused wires to prevent electrical short circuit.)
- 2** Re-connect the negative battery terminal and test the unit for proper operation.
- 3** Reassemble radio and dash assemblies in reverse order of disassembly.

FINAL WIRING CONNECTIONS

Make wiring connections using the EIA color code chart shown below and the instructions included with the head unit. Recommended connections as shown below; Strip, Splice, Solder, Tape. Isolate and individually tape off ends of any unused wires to prevent electrical short circuit.

EIA WIRING CODE

12V Ignition / Acc . . . Red	Right Front (+) Gray
12V Batt / Memory . . Yellow	Right Front (-) Gray/ Black
Ground Black*	Left Front (+) White
Power Antenna Blue	Left Front (-) White / Black
Amp Turn-On Blue / White	Right Rear (+) Violet
Amp Ground Black / White	Right Rear (-) Violet / Black
Illumination Orange	Left Rear (+) Green
Dimmer Orange / White	Left Rear (-) Green / Black

***NOTE:** When Black a wire is not present, ground radio to vehicle chassis.
All colors may not be present on all leads due to manufacturer's specifications.